

ADAM CellIT

A New Standard of Automated Cell Counter

Instruction Manual



All the materials in this instruction manual are protected by Korean and international copyright laws. They cannot be reproduced, translated, published or distributed without the permission of the copyright owner.

ADAM-CeIT Instruction Manual

Website : www.nanoentek.com

E-mail : sales@nanoentek.com

Manufactured by

NanoEnTek, Inc.

851-14, Seohaero, Paltan-myeon, Hwaseong-si, Gyeonggi-do, 18531, Korea

Tel. +82-2-6220-7940

Fax. +82-2-6220-7999

NanoEnTek America, Inc.

240 Bear Hill Road, Suite 101, Waltham, MA 02451, USA

Tel. +1-781-472-2558

Fax. +1-781-790-5649

The information in this manual is described as accurately as possible.

Firmware and software changes and updates may change without prior consent or notification.

Copyright © 2019 by NanoEnTek Inc.

All rights reserved. Published in Korea.

Documentation: **NESMU-ACT-001E**

Revision history: **V.0.0 OCT 2019**

Table of contents

Introduction

General description	2
Technology	3
Basic principle of counting	4

Product Contents

ADAM-CellT	5
AccuChip kit	5
Upon receiving the instrument	5

Product Description

Front view of ADAM-CellT	6
Rear view of ADAM-CellT	7

Getting Started

Environmental requirements	8
Power on and initial display	8
Error messages during booting	9
Count setting	10

General Operation

Introduction	11
Sample preparation	12
Counting cell	12

Measure

Run sample	15
Result analysis	16
Result analysis -Error code	17

Data

Data list	18
Edit	19
Image	20
Mail	21

Setting

Setting	22
Wifi	23
Update	23

User

User	24
User manage	25
Log manage	26
Document manage	27
Deleted list	28

Power off

Lock	29
Power off	29

Maintenance and cleaning	30
Trouble shooting	31
Warranty	32
Technical specifications	33
Product list	34
Safety precautions	35
Safety symbols	36
Warnings	37
Technical Support	38

General Description

The ADAM-CeIT, an automated cell counter, is a benchtop automated cell counter that performs cell count and viability measurements using AccuStain Solution.



Technology

Until now, cell counting and viability measurement for many types of cells have been performed manually using hemocytometer with Trypan Blue exclusion method, which is to distinguish viable cells from non-viable cells. One drawback of this method, however, is the propensity for the staining of artifacts; another drawback is that the naked eye can only differentiate between cells in a limited concentration range in the hemocytometer chamber. This combined with the potential problem of cell aggregation and limited sample volume leads to the common variation of counts normally associated with this method.

To address these problems, NanoEnTek has developed the ADAM-CellIT, which is based on a fluorescent microscopy technique for counting cells. The ADAM-CellIT utilizes sensitive fluorescence dye staining, LED optics and CMOS detection technologies to make the cell analysis more accurate and reliable.

To count cells using ADAM-CellIT, the cells are mixed with a Propidium Iodide (PI) stain and directly pipetted on to a disposable plastic chip. The chip is then loaded onto a precision stage. An ADAM-CellIT system is automatically focused onto the chip and cells that have been stained are recorded by a sensitive CMOS camera. The image results are automatically processed generating the cell count which is displayed on the front of the instrument. Simple. Fast. Accurate. Reliable.

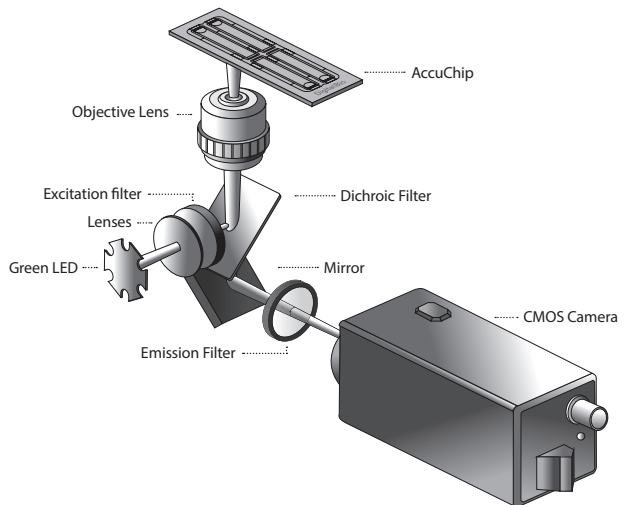

Basic principle of counting

ADAM-CeLIT is based on staining mammalian cell DNA with a fluorescent dye, Propidium Iodide (PI). PI does not enter cells with intact membranes or active metabolism. In contrast, cells with damaged membranes or with inactive metabolism are unable to prevent PI entering the cell. As a result, the nuclei of non-viable cells will only be stained. The ADAM-CeLIT provides two kinds of staining solutions. AccuStain Solution T for the total cell counting is composed of the fluorescent dye (PI) and lysis solution. AccuStain Solution N for the non-viable cell counting is composed of the fluorescent dye and PBS.

In order to measure the total concentration of cells, the plasma membranes of all the cells must be disrupted to stain all the Nuclei with PI. The process of disrupting and staining is achieved by treatment with AccuStain Solution T.

In the second solution, live cells remain intact and are not stained.

Only the non-viable cells are stained and detected. After treatment, the prepared cells will be loaded into the chip. The viability will be automatically calculated in the ADAM-CeLIT software after each measurement of the total cells and the non-viable cells.

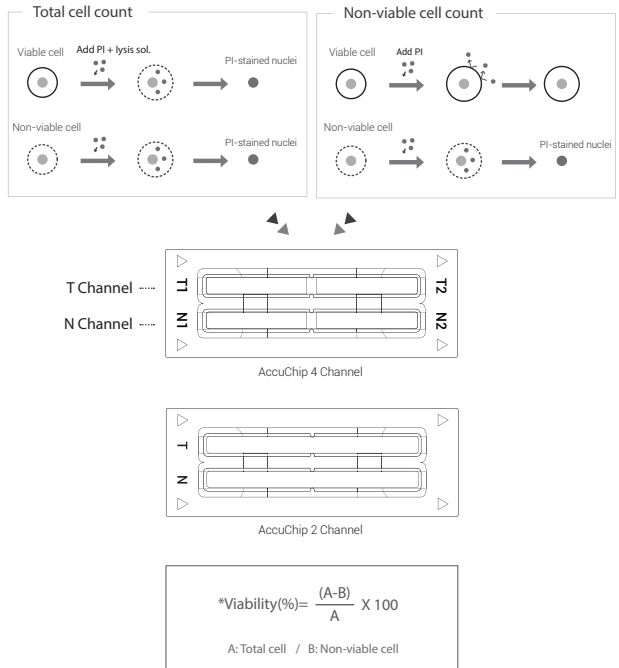

ADAM-CellIT

The contents of the ADAM-CellIT are listed below:

Item	Quantity
Main device	1
Instruction manual	1
USB hub	1
Wifi dongle	1
Power cord	1
Adapter	1
AccuChip Kit	1
Calibration Bead	1

AccuChip kit

The contents of the ADAM-CellIT's AccuChip Kit are listed below:

Item	AccuChip2x Kit (Cat. No: AD2K-200)	AccuChip4x Kit (Cat. No: AD4K-200)	AccuStain Solution (Cat. No: ADR-1000)
Disposable Chip	200pcs (2 channel)	200pcs (4 channel)	N/A
Solution T	12.5 mL x 2ea	12.5 mL x 2ea	12.5 mL x 4ea
Solution N	12.5 mL x 1ea	12.5 mL x 1ea	12.5 mL x 2ea
Available test Q'ty	Min. 200 test/kit	Min. 400 test/kit	
	Max. 400 test/kit (Only total cell count)	Max. 800 test/kit (Only total cell count)	

Upon receiving the instrument

- Examine the instrument carefully for any damage incurred during transit.
- Ensure that all parts of the instrument including accessories listed above are included with the product.
- Any damage claims must be filed with the carrier.
- The warranty does not cover in-transit damage.
- Upon receipt, store AccuChip at room temperature. AccuStain Solution should be stored at 2~8°C

Front view of ADAM-CellIT

The front view showing various parts of the ADAM-CellIT is shown below:

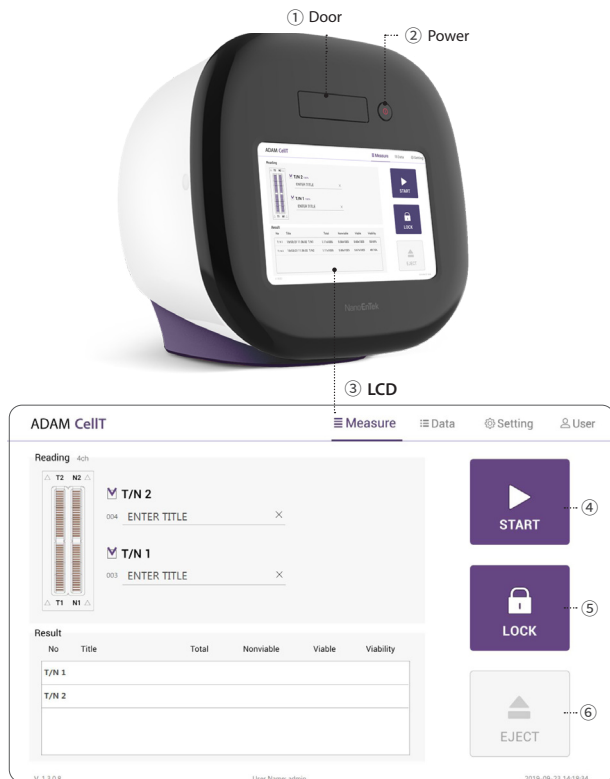

Control buttons	Description
① Door	Slide holder is inserted and ejected.
② Power	Power on / off.
③ LCD	Display processes and results.
④ START	Performs all procedures of automatic counting.
⑤ LOCK	Protects the alignment of stage from external shock when ADAM-CellIT is being moved. Lock ADAM-CellIT before turning it off or moving it.
⑥ EJECT	Ejects the slide holder from ADAM-CellIT. Functions as unload.

Rear view of ADAM-CellIT

The rear view showing various parts of the ADAM-CellIT.

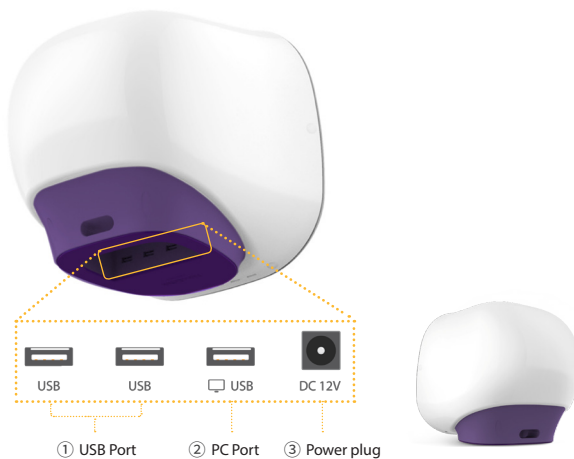

Port	Description
① USB Port	Port for software update and save the data.
③ Power Plug	Connects ADAM-CellIT power cord to wall outlet

⚠ CAUTION

Do not use the ② PC port. This port does not recognize USB.

Environmental requirements

ⓘ CAUTION

At low temperature ($\leq 10^{\circ}\text{C}$), allow the device to warm up for 10 minutes at ambient temperature before use.

To ensure correct operation and stable performance, install the ADAM-CellT in a location which meets the following conditions:

1. Use at room temperature between 20 and 35 °C
 - Not recommended for cold room use ($\leq 4^{\circ}\text{C}$).
2. Do not expose the device to direct sunlight.
3. Do not subject the device to direct or continuous vibration.
4. Do not subject the device to intense magnetic or electromagnetic fields.
5. Do not install the device in high-humidity environment.
6. Location of device should be free from corrosive gases or other corrosive substances.
7. Ensure minimal contact with dust or other airborne particles.
8. Allow a 10 cm (4 inches) minimum space around the device for proper airflow.
9. Do not place any objects on the device.

Power on and Initial Display

1. Check the connection of ADAM-CellT and power cord.
2. Press the power button for 2~3 seconds.

If you get an error message, please contact your local distributor or sales@nanoentek.com.

If booting is successful and no errors are detected, the home screens will be displayed as below.

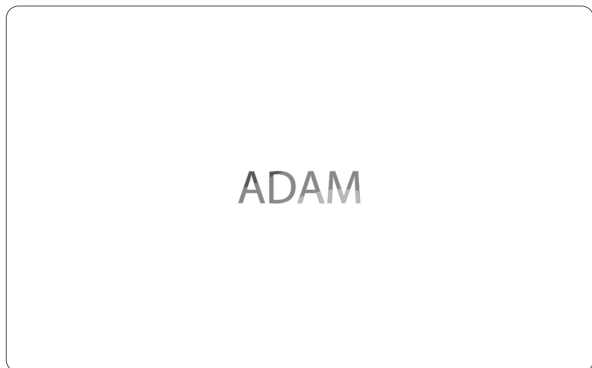

ⓘ CAUTION

- Do not tilt the device too much in the forward when connecting the power cord.
- Do not move the device after connecting power cord.
- When you connect the power cord to ADAM-CellT even without power on the device, it will go through self diagnostic tests.

Error Messages during booting

[System State]

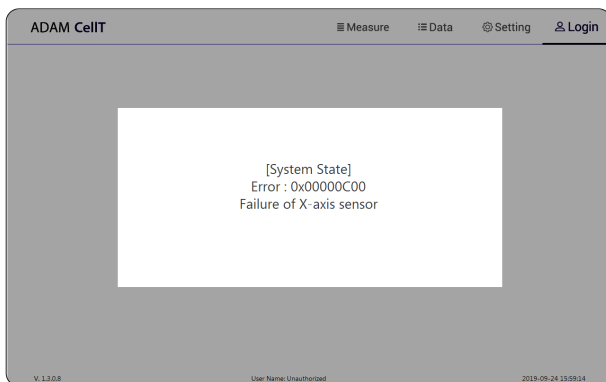

It appears when booting is not working properly.
Turn off main power and restart device.

If this message still appears after restarting,
contact your local distributor or sales@nanoentek.com.

Error code	Cause
0x00000C00	Failure of X-axis sensor
0x00007000	Failure of Y-axis sensor
0x00008000	Failure of Z-axis sensor
0x06000000	Failure of Locking module sensor

Count setting

Set the conditions in the 'Setting' tap before counting.

[AccuChip]

Set the AccuChip according to you are using.

Accuchip

4Ch 2Ch



Accuchip

4Ch 2Ch



[Cell size]

Set the minimum and maximum size of cell.

Cell size

Min 5 Max 80

[Dilution factor]

When diluting sample, set the Dilution factor.

! CAUTION

Factor values for the AccuStain Solution is already applied.

Dilution factor

1.0

Introduction

Instructions are provided in this section for preparing the sample with AccuStain Solution for use with disposable AccuChip for automated cell count using the ADAM-CellIT.

Please check the procedure of sample preparation and testing below. For more detailed information, please refer to the next page.

1. Mix the sample with AccuStain Solution.

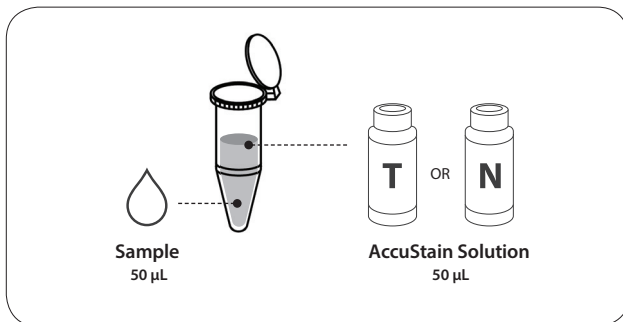

2. Load the mixed sample. Then, wait 1 minute for the sample settling.

- [2 channel: 23µL
- 4 channel: 13µL
- [T channel: Total cell
- N channel: Non-viable cell

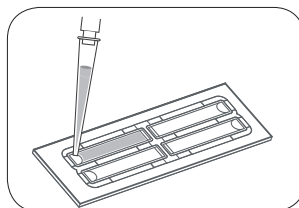

3. Insert AccuChip. Get the result.

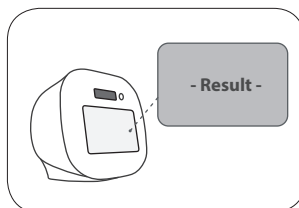
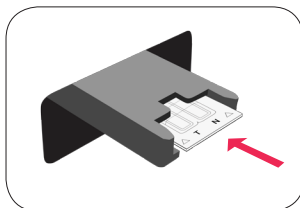

Sample preparation

1. Cultivate the required number of cells.
2. Add an appropriate volume of growth media or PBS to dilute to a final concentration of 5×10^4 cells/mL to 4×10^6 cells/mL.

NOTE Concentration out of this range will result in errors.
Refer to page 17 for more information about errors.

3. Thoroughly mix the cell pellet by vortexing.
4. Check visually if any cell clumps or agglomerates are remained.

Counting cell

[AccuChip 2x]

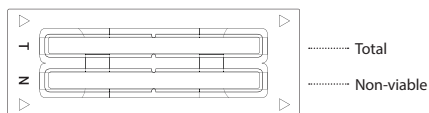

Total Cell	Non-viable Cell
1) Add 50 μ L of your sample to 50 μ L supplied AccuStain Solution T.	1) Add 50 μ L of your sample to 50 μ L supplied AccuStain Solution N.
2) Voltex the tube vigorously.	2) Voltex the tube vigorously.
3) Load 23 μ L sample mixture to the AccuChip on T channel. Then, wait 1 minute for the sample settling.	3) Load 23 μ L sample mixture to the AccuChip on N channel. Then, wait 1 minute for the sample settling.

[AccuChip 4x]

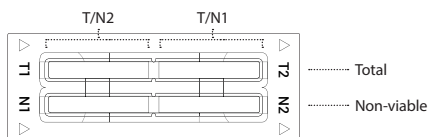

Total Cell	Non-viable Cell
1) Add 50 μ L of your sample to 50 μ L supplied AccuStain Solution T.	1) Add 50 μ L of your sample to 50 μ L supplied AccuStain Solution N.
2) Voltex the tube vigorously.	2) Voltex the tube vigorously.
3) Load 13 μ L sample mixture to the AccuChip on T1 or T2 channel. Then, wait 1 minute for the sample settling.	3) Load 13 μ L sample mixture to the AccuChip on N1 or N2 channel. Then, wait 1 minute for the sample settling.

NOTE When you load of the sample mixture to the AccuChip, please be careful not to make bubbles.

Counting cell

⚠ WARNING

[Sample loading error]

Be cautious of loading the correct volume of the sample into AccuChip. The instrument will not detect low or high sample volumes.

Correct volume

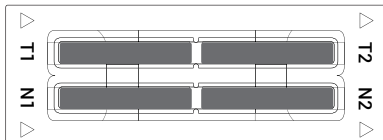

Low volume

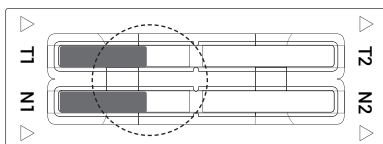

⚠ CAUTION

Avoid bubbles which may negatively affect the result.

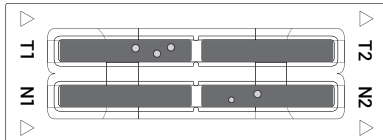

Counting cell

⚠ WARNING

[AccuChip insert error]

Completely insert AccuChip face up, in the direction of the arrow on the slide. The instrument will not detect if slides are inserted incorrectly. See pictures below for proper insertion.

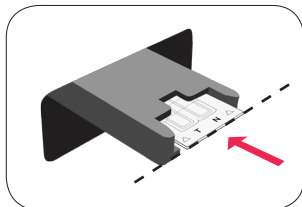

(O)

Correctly inserted

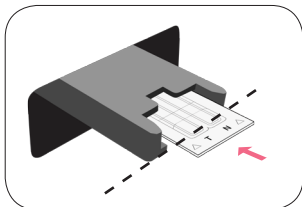

(X)

Not fully inserted

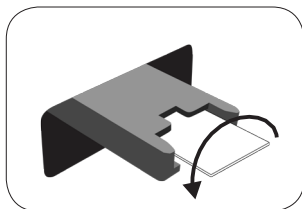

(X)

Upside down inserted

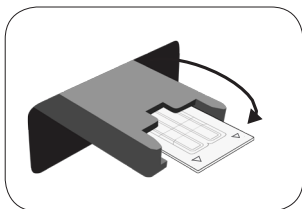

(X)

Wrong direction inserted

⚠ CAUTION

- Please insert or remove the AccuChip when the slide holder is fully ejected.
- When the test is finished, please remove the AccuChip from the slide holder.

Run Sample

Start counting process by pressing 'START'
 It may take about 2 minutes longer for auto focus at the initial test.

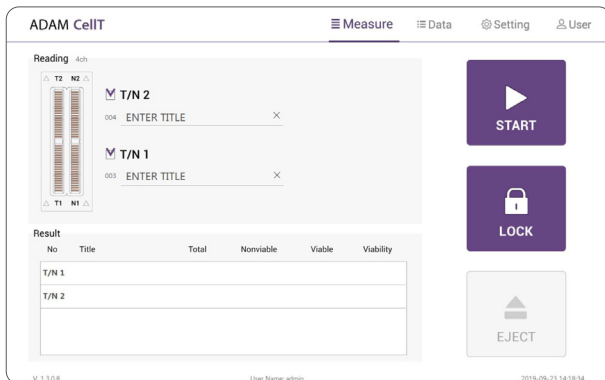

While the test is in progress, you can check the cell images of each channel.

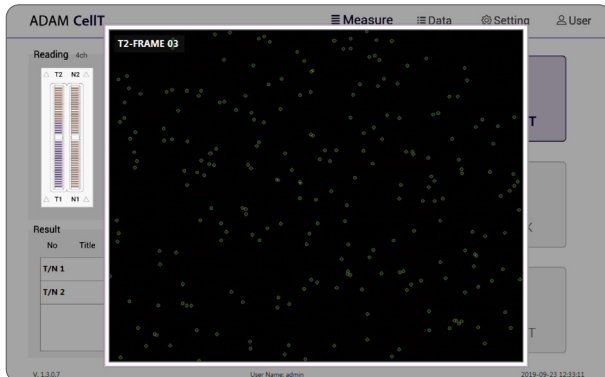

Result Analysis

The result will be displayed after being automatically calculated by ADAM-CELLT software.

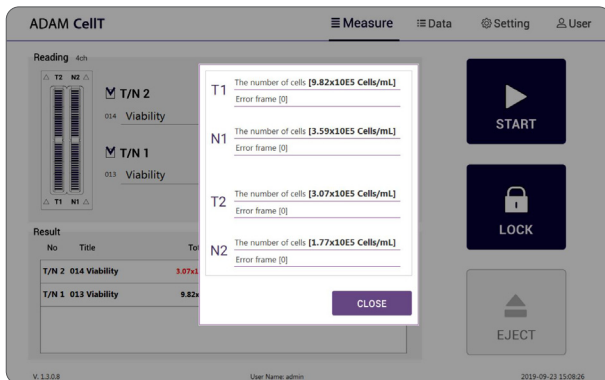

* 1.10E6 = 1.10 X 10⁶ cells/mL

Title	Number of Total cell	Number of Non-Viable cell	Viability
Viability 01	T1 (1.10E6)	N1 (5.50E5)	50%
Viability 02	T2 (2.20E6)	N2 (5.50E5)	75%

- The viability will be automatically calculated by the ADAM-CELLT software after each measurement of the total cells and the non-viable cells.
- First, the total cell number and second, non-viable cell number were measured and then the cell viability is calculated as subtracting non-viable cell counting numbers from total cell counting.

Result Analysis - Error code

The screenshot shows the ADAM CellIT software interface. At the top, there are navigation icons for Measure, Data, Setting, and User. The main area is divided into 'Reading' and 'Result' sections. The 'Reading' section shows a bar chart and two sample configurations: T/N 2 (012 3x sample) and T/N 1 (011 3x sample). The 'Result' section contains a table with columns: No, Title, Total, Nonviable, Viable, and Viability. Two rows of data are shown, with the 'Nonviable' column values highlighted in red and enclosed in a red box. Below the table, there are control buttons: 'START' (play icon), 'LOCK' (lock icon), and 'EJECT' (eject icon). At the bottom, there is a version number 'V. 1.3.0.0', a user name 'Name: admin', and a timestamp '2019-09-23 14:46:14'.

No	Title	Total	Nonviable	Viable	Viability
T/N 2 010	3x sample	1.07x10E6	3.38x10E5 (E)	7.30x10E5	68.37 %
T/N 1 009	3x sample	1.07x10E6	3.35x10E5 (E)	7.37x10E5	68.75 %

Error code	Cause
E	Frames with errors are over 50% of total counting frame.
O	Cells are more than 4×10^6 cells/mL.
H	Cells are more than 2×10^6 cells/mL.
L	Cells are less than 4×10^5 cells/mL.
U	Cells are less than 5×10^4 cells/mL.
Error frame [#]	<p>Frame with error that contains cells whose diameter is larger than $100 \mu\text{m}$.</p> <p>When this error shown in result window, please check the image.</p>

Data list

ADAM CellIT Measure **Data** Setting User

Data List

①	All	No	Sample	Date	Time	Total	Nonviable	Viable	Viability	Backup	Start Date	End Date
<input type="checkbox"/>	51	CH4	010 3x sample	2018/09/23	14:45:11	1.07x10E6	3.38x10E5 (L)	7.30x10E5	68.37 %	X	2019 / 09 / 23	2019 / 09 / 23
<input type="checkbox"/>	52	CH4	009 3x sample	2018/09/23	14:45:11	1.07x10E6	3.35x10E5 (L)	7.37x10E5	68.75 %	X	2019 / 09 / 23	2019 / 09 / 23
<input type="checkbox"/>	51	CH4	008 5x sample	2018/09/23	14:43:27	1.03x10E6	5.24x10E5	5.03x10E5	48.97 %	X	SEARCH	
<input type="checkbox"/>	50	CH4	007 5x sample	2018/09/23	14:43:27	1.04x10E6	5.32x10E5	5.11x10E5	48.96 %	X	EDIT	
<input type="checkbox"/>	49	CH4	006 sample 07	2018/09/23	14:30:40	1.00x10E6	9.81x10E5	1.52x10E4	1.53 %	X	IMAGE	
<input type="checkbox"/>	48	CH4	005 sample 08	2018/09/23	14:30:40	9.90x10E5	1.04x10E6	0.00x10E0	0.0 %	X	SAVE	
<input type="checkbox"/>	47	CH4	004 sample 04	2018/09/23	14:29:01	0.00x10E0 (L)	0.00x10E0 (L)	0.00x10E0	0.0 %	X	DELETE	
<input type="checkbox"/>	46	CH4	003 sample 05	2018/09/23	14:29:01	1.09x10E5 (L)	0.00x10E0 (U)	1.09x10E5	100.0 %	X	MAIL	
<input type="checkbox"/>	45	CH4	006 dds	2018/08/22	15:38:25	1.05x10E6	1.08x10E6	0.00x10E0	0.0 %	X		
<input type="checkbox"/>	44	CH4	005 dds#01	2018/08/22	15:38:25	1.13x10E6	1.07x10E6	6.27x10E4	5.56 %	X		
<input type="checkbox"/>	43	CH4	004 Sam_1	2018/08/21	13:23:57	1.09x10E6	1.10x10E6	0.00x10E0	0.0 %	X		

V.1.3.0.8 User Name: admin 2019-09-23 14:55:10

Control buttons	Description
① All	Select all data in Data List.
② SEARCH	Display the data of the selected date.
③ EDIT	View and edit the data. Multiple data can be edited with the same settings.
④ IMAGE	Check the cell images of each channel.
⑤ SAVE	Save the selected data to USB(PDF, Excel, Image).
⑥ DELETE	Delete the selected data.
⑦ MAIL	Send the Excel, PDF, and Image files of selected data to e-mail.

EDIT

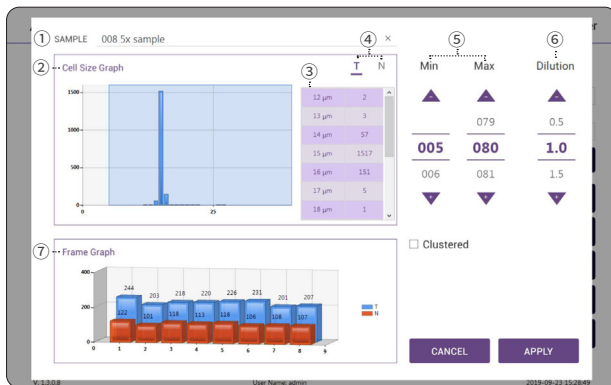

Control buttons	Description
① Sample	Edit the sample name.
② Cell size graph	View the cell size graph each channel(T/N).
③ Cell size table	View the number of cells in each cell size.
④ Channel	Select a channel(T/N).
⑤ Cell size setting	Set the min/max size of the cell.
⑥ Dilution Factor	Set the dilution factor of sample. Factor values for the AccuStain Solution is already applied.
⑦ Frame graph	View the counted cell number of each frame.

IMAGE

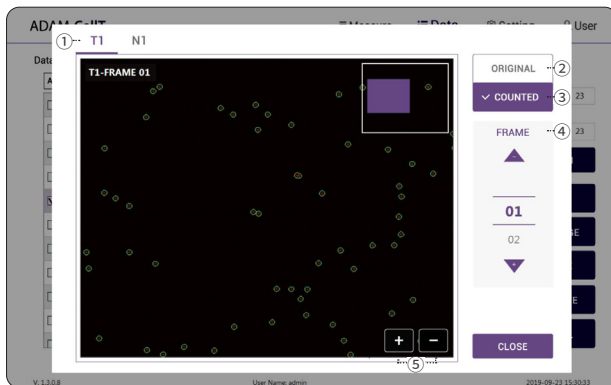

Control buttons	Description
① Channel	Select a channel.
② Original	Check the original image.
③ Counted	Check the counted cell image.
④ Frame	Select a frame number of the channel.
⑤ Zoom-in/out	Zoom in and out to check the cell image.

MAIL

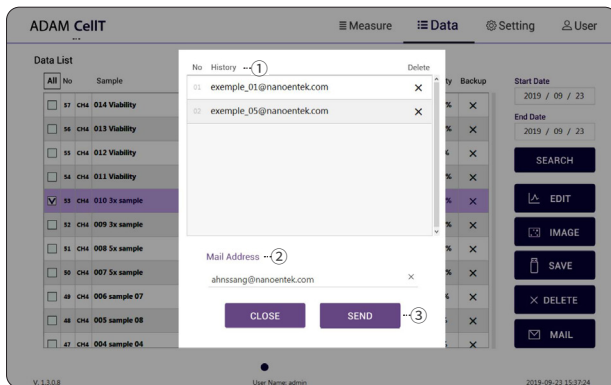

Control buttons	Description
① History	Select an e-mail address from the list to send the Excel, PDF, and Image files of selected data. The e-mail address that received the files remains in the list.
② Mail Address	If you want to receive files by new e-mail, please enter the e-mail address.
③ Send	Send the files to a selected e-mail address. Files can be sent to only one e-mail at a time.

Setting

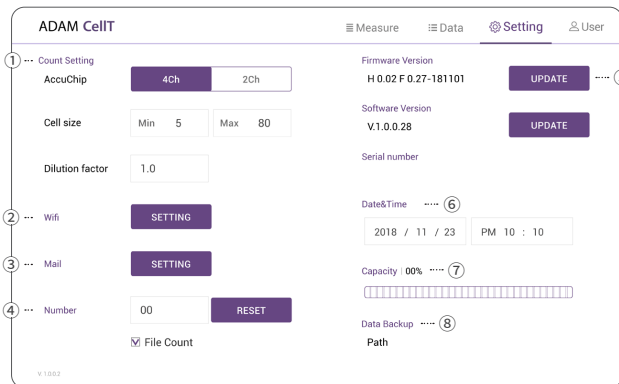

Control buttons	Description
① Count setting	Set the conditions in the setting tap before counting. Refer to page 10 for more information.
② Wifi	Set the wifi to use the e-mail function.
③ Mail	Do not change the setting in mail.
④ Number	Select Auto-Numbering
⑤ Update	Firmware or Software update through the USB.
⑥ Date&Time	Set the current date and time.
⑦ Capacity	Check remaining capacity.
⑧ Data Backup	View the storage path of additional data backup.

Wifi

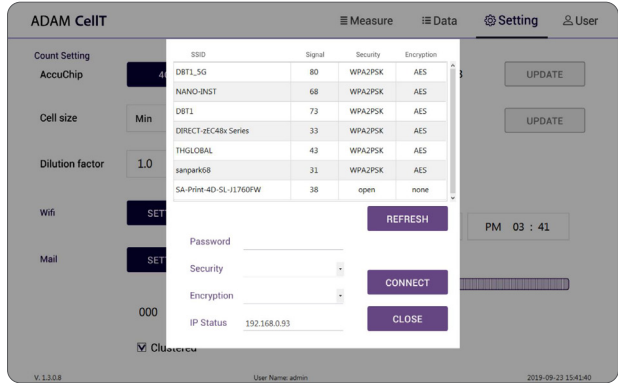

1. Click the Refresh button.
2. Select the wifi.
3. Insert the password of selected wifi.
4. Click the Connect button.

CAUTION

If connection error occurs, please contact a laboratory facility manager.

Update

1. Prepare the USB with update file.
2. Insert the USB.
3. Click the UPDATE button.

CAUTION

- The 'AdamUpdate' folder must exist in the root path of the USB folder.
- ADAM-CellT can be updated only when the firmware or software file exists in the 'AdamUpdate' folder. The 'ADAM CellT.eve' file should be in the 'AdamUpdate' folder.
- Do not rename the 'AdamUpdate' folder. The folder name should be 'AdamUpdate'.

User

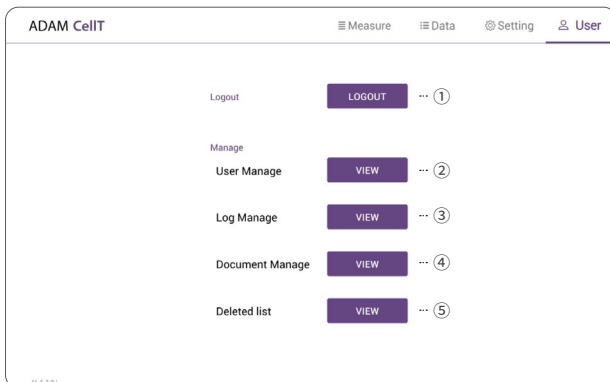

Control buttons	Description
① Logout	Logout
② User manage	Register user.
③ Log manage	Track user access records.
④ Document manage	Track management document records.
⑤ Deleted list	Track deleted data records.

• ADAM-CellIT provides a comprehensive solution to comply with the requirements of the 21 CFR Part 11 rule.

• Please see the appendix for more information on these features.

User manage

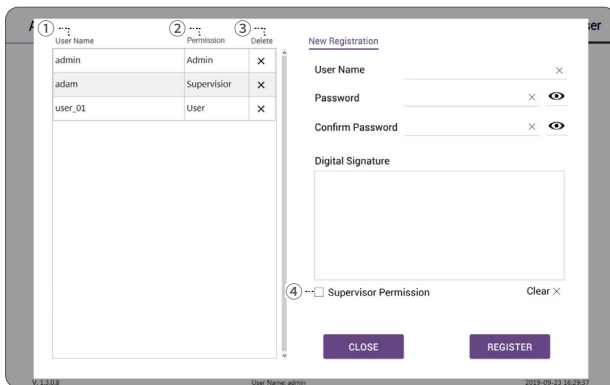

Control buttons	Description
① User Name	View the registered user list.
② Permission	View the user access authority.
③ New Registration	Register new user.
⑤ Supervisor permission	Register as a supervisor.

Log manage

The screenshot shows a 'Log Management' window for the period 2019/09/23 - 2019/09/23. It features a table with columns: Date, Time, DeviceType, UserName, UserType, and Log. The table contains multiple rows of log entries. On the right side, there are date selection controls for 'Start Date' and 'End Date', both set to 2019/09/23. Below these are five control buttons: SEARCH, SAVE, DELETE, and CLOSE, each with a corresponding icon and a circled number (2, 3, 4, 5) next to it. A circled number 1 is next to the 'All' filter button at the top left of the table.

Control buttons	Description
① All	Select all data in Data List.
② SEARCH	Display the data of the selected date.
③ SAVE	Save the selected data to USB.
④ DELETE	Delete the selected data.
⑤ CLOSE	Close the log manage.

Document manage

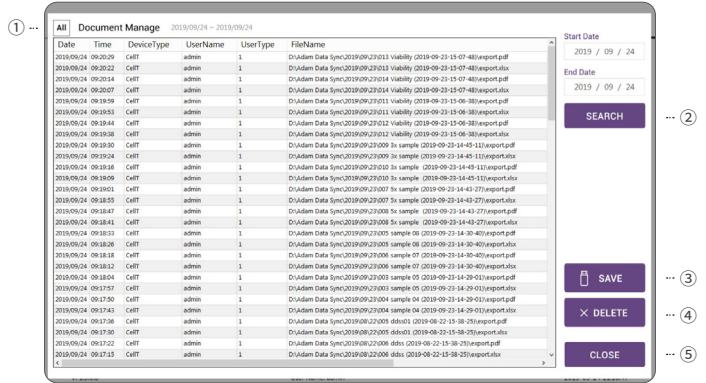

Control buttons	Description
① All	Select all data in Data List.
② SEARCH	Display the data of the selected date.
③ SAVE	Save the selected data to USB.
④ DELETE	Delete the selected data.
⑤ CLOSE	Close the document page.

Deleted list

① ...

All Deleted result list Manage 2019/09/24 ~ 2019/09/24

Name	Date	Time	Sample_Index	Total	Total2	Total_Count	Dead	Dead2	Dead_Count	Live
19-07-31 150453 T-N 1	2019/07/31	150454	1	0.00x10E3	(U)	0	0.00x10E0	(U)	0	0.00x10E3
19-07-31 150454 T-N 2	2019/07/31	150454	2	0.00x10E3	(U)	0	1.13x10E5	(U)	113360	0.00x10E3
19-07-31 150300 T-N 1	2019/07/31	150300	1	1.03x10E6	(U)	1033996	1.03x10E6	(U)	1032117	1.79x10E3
19-07-31 150300 T-N 2	2019/07/31	150300	2	1.08x10E6	(U)	1077514	1.19x10E6	(U)	1294649	0.00x10E3
19-07-31 150021 T-N 1	2019/07/31	150021	1	9.73x10E5	(U)	970561	9.10x10E5	(U)	933807	5.22x10E3
19-07-31 150021 T-N 2	2019/07/31	150021	2	9.69x10E5	(U)	969388	1.14x10E6	(U)	1144147	0.00x10E3
19-07-31 145632 T-N 1	2019/07/31	145632	1	0.00x10E3	(U)	0	0.00x10E0	(U)	0	0.00x10E3
19-07-31 145632 T-N 2	2019/07/31	145632	2	5.86x10E2	(U)	586	0.00x10E0	(U)	0	5.86x10E2
19-07-31 145306 T-N 2	2019/07/31	145306	2	5.86x10E2	(U)	586	5.86x10E2	(U)	586	0.00x10E3
19-07-31 145306 T-N 1	2019/07/31	145306	1	5.86x10E2	(U)	586	0.00x10E0	(U)	0	5.86x10E2
19-07-31 144857 T-N 1	2019/07/31	144857	1	5.86x10E2	(U)	586	0.00x10E0	(U)	0	5.86x10E2
19-07-31 144857 T-N 2	2019/07/31	144857	2	0.00x10E3	(U)	0	0.00x10E0	(U)	0	0.00x10E3
19-07-31 144640 T-N 1	2019/07/31	144640	1	5.86x10E2	(U)	586	0.00x10E0	(U)	0	5.86x10E2
19-07-31 144640 T-N 2	2019/07/31	144640	2	1.17x10E3	(U)	1173	5.86x10E2	(U)	586	5.86x10E2
19-07-31 143807 T-N 1	2019/07/31	143807	1	8.47x10E5	(U)	847425	9.78x10E5	(U)	924320	0.00x10E3
19-07-31 143807 T-N 2	2019/07/31	143807	2	9.01x10E5	(U)	900788	9.78x10E5	(U)	978451	0.00x10E3
01	2019/07/31	141349	2	9.30x10E5	(U)	905538	1.00x10E6	(U)	1004704	0.00x10E3
01	2019/07/31	141303	2	8.53x10E5	(U)	815364	9.50x10E5	(U)	981215	0.00x10E3
02	2019/07/31	141303	1	8.75x10E5	(U)	874535	8.53x10E5	(U)	852058	2.19x10E3
01	2019/07/31	140738	2	8.56x10E5	(U)	836417	9.76x10E5	(U)	976263	0.00x10E3
02	2019/07/31	140738	1	8.66x10E5	(U)	807972	8.14x10E5	(U)	844454	2.21x10E3
01	2019/07/31	140318	2	9.63x10E5	(U)	962500	1.07x10E6	(U)	1074710	0.00x10E3
02	2019/07/31	140318	1	9.26x10E5	(U)	823946	9.50x10E5	(U)	959309	0.00x10E3
01	2019/07/31	137140	2	9.30x10E5	(U)	905538	1.10x10E6	(U)	1100426	0.00x10E3
02	2019/07/31	137140	1	8.68x10E5	(U)	807506	9.76x10E5	(U)	923399	0.00x10E3
19-07-31 113807 T-N 2	2019/07/31	113807	2	6.44x10E5	(E)	643732	6.72x10E5	(E)	672127	0.00x10E3
19-07-31 113807 T-N 1	2019/07/31	113807	1	6.13x10E5	(E)	633341	6.43x10E5	(E)	643185	0.00x10E3

Start Date: 2019 / 09 / 24
End Date: 2019 / 09 / 24

SEARCH

SAVE

DELETE

CLOSE

②

③

④

⑤

Control buttons	Description
① All	Select all data in Data List.
② SEARCH	Display the data of the selected date.
③ SAVE	Save the selected data to USB.
④ DELETE	Delete the selected data.
⑤ CLOSE	Close the deleted list.

Lock

Press  LOCK before turning off the device.

If there is no operation for 3 minutes, the lock function will be activated automatically.

When the device is locked, the screen will be changed as shown below.

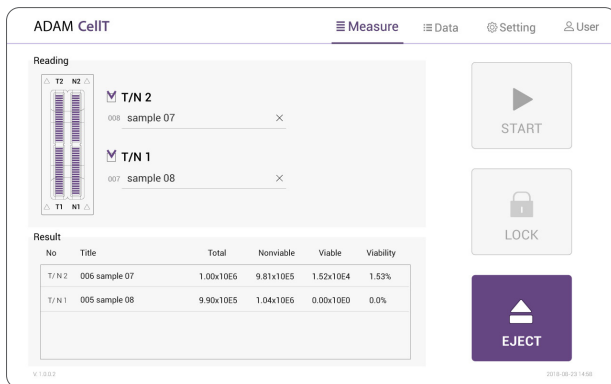

Power off

If you press the power button for 2~3 seconds, then 'Slide to shut down your PC' message will appear. Slide down the screen to turn off the power.

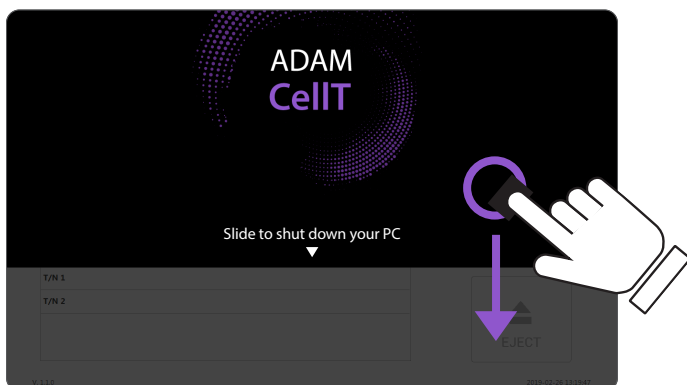

Maintenance and cleaning

1. ADAM-CellT does not need regular maintenance.
2. ADAM-CellT has no replacement of consumable materials.
3. Please clean the exposed surface of ADAM-CellT frequently or before testing, using a soft cloth and isopropyl alcohol or deionized water.

ⓘ CAUTION

Dispose of wipes in an appropriately labeled solvent contaminated waste container.

Trouble shooting

Problem	Description	Solution
ADAM-CellT does not power up	<ul style="list-style-type: none"> No power from outlet Bad power cord. 	<ul style="list-style-type: none"> Check power source. Replace.
Inaccurate result	<ul style="list-style-type: none"> Cell number may be out of range. AccuStain Solution has expired. Too high clumped cells. 	<ul style="list-style-type: none"> Adjust the number of cells between $5 \times 10^4 \sim 4 \times 10^6$ cells/mL (refer to page 12). Discard AccuStain that have expired. Purchase the AccuStain(ADR-1000). Try again after vortexing the cells.
When error message is shown (For information on each error message, see page 17)	<ul style="list-style-type: none"> When frames with errors are over 50% of total counting frame. (Error message: E) 	<ul style="list-style-type: none"> Check the suspension of cells if all cells are fully dissociated into single cells. If contaminants except cells are found, prepare sample again.
	<ul style="list-style-type: none"> When over 100μm diameter of cells are included. (Error message: Error frame [#]) 	<ul style="list-style-type: none"> Check fully dissociated into single cells.
	<ul style="list-style-type: none"> High concentration of cells (Error message: H) Over detection range (Error message: O) 	<ul style="list-style-type: none"> Check if concentration of cell is too high. Dilute the sample and count again.
	<ul style="list-style-type: none"> Low concentration of cells (Error message: L) Under detection range (Error message: U) 	<ul style="list-style-type: none"> Check if concentration of cell is too low. Use concentrated sample and count again.

Warranty

If any defects occur in the ADAM-CellIT during one(1) year warranty period, NanoEnTek will repair or replace the defective parts at its discretion without charge. The following defects, however, are specifically excluded:

1. Defects caused by improper operation.
2. Repair or modification done by anyone other than NanoEnTek or an authorized agent.
3. Damage caused by substituting alternative parts.
4. Use of fittings or spare parts supplied by anyone other than NanoEnTek.
5. Damage caused by accident or misuse.
6. Damage caused by disaster.
7. Corrosion caused by improper solvent or sample.

For your protection, items being returned must be insured against possible damage or loss. NanoEnTek cannot be responsible for damage incurred during shipment of a repair instrument. It is recommended that you save the original packing material in which the instrument was shipped. This warranty should be limited to the replacement of defective products.

For any inquiry or request for repair service,
Contact sales@nanoentek.com or your local distributor.

Technical Specifications



ADAM-CellIT	
Measuring range	5x10 ⁴ ~ 4x10 ⁶ cells/mL
Optimal range	5x10 ⁵ ~ 2x10 ⁶ cells/mL
Analysis time	< 25~50 sec/test <small>: For initial test, max 2 min/test</small>
Voltage	DC12V
Current	5A
Objective lens	4 X
LED	4W Green LED
Camera	CMOS camera
Filter	Excitation filter, Dichroic filter, Emission filter
Weight	7 Kg
Size (W×L×H)	227 × 276 × 270 mm
Degree of protection	IPX0

Operating environment condition

Temperature	0 °C ≤ Temperature ≤ 40 °C
Humidity	10 % ≤ Humidity ≤ 90 %
Altitude	Altitude ≤ 2,000 m

Transportation & storage environment condition

Temperature	-30 °C ≤ Temperature ≤ 60 °C
Humidity	10 % ≤ Humidity ≤ 90 %

AccuChip Kit



AccuChip 2x



AccuChip 4x

AccuChip	
Loading sample vol. per test	23 μL/test (AccuChip 2X)
	13 μL/test (AccuChip 4X)
Measuring sample vol. per test	8.6 μL/test (AccuChip 2X)
	3.4 μL/test (AccuChip 4X)



Solutions	
AccuStain Solution	12.5 mL, Propidium Iodide (PI) Total cells (T), non-viable cells (N)

Storage temperature

AccuChip	0 – 30 °C
AccuStain Solution	2 – 8 °C

Shelf-life

AccuChip	2 year
AccuStain Solution	1 year

Product List

Cat. No.	Product	Contents	Quantity
AD2K-200	AccuChip2X Kit*	200 pcs AccuChip 2X	1
		12.5 mL AccuStain Solution T	2
		12.5 mL AccuStain Solution N	1
AD4K-200	AccuChip4X Kit	200 pcs AccuChip 4X	1
		12.5 mL AccuStain Solution T	2
		12.5 mL AccuStain Solution N	1
ADR-1000	AccuStain	12.5 mL AccuStain Solution T	4
		12.5 mL AccuStain Solution N	2
ADB-500	ADAM Calibration Bead	5 mL Calibration Bead	1

**AccuChip 2x: please consult your distributor or manufacture for availability.*









Safety Precautions

Review and follow the safety instructions below :

- Always ensure that the power supply input voltage matches the voltage available at your location.
- To avoid the danger of electric shock, install the instrument per the environmental specifications located in "Technical Specifications". If water or other material enters the instrument, the adaptor, or power inlet, disconnect the power cord and contact a service person.
- Do not touch the main plug or power cord with wet hands.
- This machine is air-cooled so its surfaces become hot during operation. During installation and use, leave more than 10 cm (4 inches) free around the device.
- Do not install the instrument on a slant or a place prone to vibrations or the risk of instrument malfunction or damage to the instrument will increase.
- Never insert any objects (especially metallic) into the air vents of the instrument as this could result in electrical shock, personal injury, and equipment damage.
- Always set the main switch on the power supply unit to OFF before connecting the power cord to the wall outlet.
- To avoid a potential shock hazard, always connect the grounding terminal of the instrument and that of the wall outlet properly. The power cord should be connected to a grounded, 3-conductor power outlet.
- Position the device so that there is sufficient length for the cables and their respective connections.
- Set the main switch to "O" (OFF), unplug the power cord, and lock the stage before moving.
- If the instrument is broken or dropped, disconnect the power cord and contact an authorized service person. Do not disassemble the instrument.
- Only use authorized accessories.
- Use this equipment only as specified in this manual and as specified in any documentation associated with its components. Use of the equipment in an unspecified manner may result in damage to the device or injury to the user.

Safety Symbols

The following symbols are found on the instrument and this document. Always use the equipment in the safest possible manner.

Symbol	Meaning
	Caution & Warning
	ON/OFF (Power)
	This instrument and consumables conforms to the EC Declaration of Conformity.
	Caution: BIOHAZARD Protective measures must be used in dealing with biologically hazardous materials such as carcinogenic reagents.
	USB Connection
	LED
	<p>Disposal of your old appliance</p> <ol style="list-style-type: none"> 1. When this crossed-out wheeled bin symbol is attached to a product it means the product is covered by the European Directive 2012/19/EU. 2. All electrical and electronic products should be disposed of separately from the municipal waste stream via designated collection facilities appointed by the government or the local authorities. 3. The correct disposal of your old appliance will help prevent potential negative consequences for the environment and human health. 4. For more detailed information about disposal of your old appliance, please contact your city office, waste disposal service or visit our web-site, www.nanoentek.com.
	This product conforms to UL 61010-1, CAN/CSA C22.2 No.61010-1 "Safety Requirements for Electrical Equipment for Measurement, Control, and Laboratory Use, Part 1: General Requirements." Instruments bearing the TUV symbol are certified by TUV SUD America Inc. to be in conformance with the applicable safety standard for the US and Canada.

Warnings

1. After using device, please turn off main power.

If not, it may cause malfunction or may reduce product life.

2. When turn off the device, be sure to lock the device with Lock button.

If not, it may cause mechanical problem or error message when device is booting.

Item	Warning
Battery inside device	<ul style="list-style-type: none"> • Risk of explosion if battery is replaced incorrectly. • This battery is not replaceable by user. Refer to an authorized service person.
Cover	<ul style="list-style-type: none"> • Do not remove cover or disassemble case. There are no adjustable components inside the instrument. • If a malfunction is found, refer to an authorized service person.
Manual	<ul style="list-style-type: none"> • Do not attempt to service the equipment. • This manual is only available in English. • Failure to heed warnings may result in injury to service provider or operator.
Sample handling	<ul style="list-style-type: none"> • Wear personal protective equipment during sampling and testing. • Sample may contain infectious or bio-hazardous agents. • Use capped tubes and lint free wipes. Lint free wipes to be used one time and discarded.
Waste	<ul style="list-style-type: none"> • After using AccuChip, appropriately dispose as bio-hazardous waste. • Do not reuse AccuChip.

Technical Support

Visit the our Website at www.nanoentek.com for :



- Technical resources, including manuals, FAQs, etc.
- Technical support contact information
- Additional product information and special offers.

For more information or technical assistance, please call or email.

NanoEnTek, Inc.

851-14, Seohae-ro, Paltan-myeon, Hwaseong-si, Gyeonggi-do, 18531, Korea
Tel. +82-2-6220-7940
Fax. +82-2-6220-7999

NanoEnTek America, Inc.

240 Bear Hill Road, Suite 101, Waltham, MA 02451, USA
Tel. +1-781-472-2558
Fax. +1-781-790-5649

Email

sales@nanoentek.com

Website

www.nanoentek.com

ADAM CellT

NESMU-ACT-001E (V.0.0)

NanoEnTek

NanoEnTek, Inc.

851-14, Seohae-ro, Paltan-myeon, Hwaseong-si,
Gyeonggi-do, 18531, Korea

Tel :+82-2-6220-7940
Fax:+82-2-6220-7999

NanoEnTek America, Inc.

240 Bear Hill Road, Suite 101, Waltham, MA 02451, USA

Tel: +1-781-472-2558
Fax: +1-781-790-5649

Email

sales@nanoentek.com

Website

www.nanoentek.com